

Ian Bennie & Associates

Test Report No. 2021-009-S3

Finesse Passive 80 Entry Door

Specimen tests by the methods of AS:4420.1-2016

To the requirements of AS:2047-2014

For

Finesse Window systems Australia Pty Ltd

March 2022



Accredited Laboratory No. 2371
Accredited for compliance with ISO/IEC 17025 - Testing



TEST REPORT NUMBER 2022-009-S3

Test Client: Finesse Window systems Australia Pty Ltd
17-23 Bancell St, Campbellfield, VIC, 3061

Specimen identification:

A Finesse Passive 80mm Entry Door sample measuring 2100 mm in height x 900 mm in width was provided by the client for testing. Client drawings of the sample details are given in Appendix B.
Drawings received Date; 30th March 2022

Test Method:

Structural Deflection, Air Infiltration, Operating Force, Water Penetration Resistance and Ultimate Strength test performance requirements to Section 2 of Australian Standard AS2047-2014, and test procedures to Australian Standard AS4420.1-2016 as detailed in Appendix A.

Test Location: Ian Bennie & Associates, Dandenong South, Victoria

Test Date: 27th January, 11th February & 15th March 2022 **Sample received:** 27th January 2022

Test Results

Pre-loading: The sample was operated five (5) times prior to the commencement of testing.

Deflection Test 1: 11th February 2022

Sample was tested to an initial positive load of 1.5kPa and then to pressures of 0.5kPa, 1.0kPa & at a load of 1.3kPa the door slipped its multipoint stays on the hinge side of the door resulting in the door being unstable in the opening.

After deflection test 1 the travel on the multipoint stays was adjusted to provide better contact.

Water penetration Test 2 - 11th February 2022

Pressure: 450 Pa PASS

No Water was observed on the indoor face of the sample during the test.

Pressure: 600 Pa

Water was observed at 1 location(s) on the indoor face of the sample during the test.

1/ water coming through the door handle lock, this leak constitutes a failure

After water test 2, the door lock system was replaced entirely.

Water penetration Test 3 - 15th March 2022

Pressure: 600 Pa PASS

No water was observed on the indoor face of the sample during the test.

Ultimate Strength Test: 17th March 2022

Test Pressures: +2750 Pa PASS

No sign of collapse was observed at either test pressure.

Test Pressures: -3250 Pa PASS

No sign of collapse was observed at either test pressure.

Test Pressures: +3000 Pa

The Door sash slipped its multipoint stays as the load was reached leaving the window unstable in the opening.

Conclusion:

The Finesse Passive 80mm entry door sample complied with the following ratings per Australian Standard AS2047-2014 when tested for Structural Deflection, Air Infiltration, Operating Force, Water Penetration Resistance and Ultimate Strength.

Housing Ratings:

Position on House	Exposure Condition	
	Non-exposed	Exposed
General	N4	N4
Corner	N3	N3

Residential and Commercial Building Ratings:

Serviceability Limit State Pressure Rating: +1610 Pa and -1600 Pa

Ultimate Limit State Pressure Rating: +2750 Pa and -3250 Pa

Air Infiltration Level: High

Water Penetration Resistance Pressure: 600 Pa

Disclaimer:

Sample information including material properties and detailing was supplied by the client and no verification of actual construction details or sampling of production stock could be performed. The test results contained herein apply to the sample as tested. Ian Bennie & Associates accept no liability for claims of losses, expenses, damages and costs arising as a result of the use of product(s) referred to in this report.

This report shall not be reproduced except in full.

Report distribution:

Ian Bennie & Associates

PDF

Finesse Window Systems Australia Pty Ltd

PDF



Ian Bennie 18th May 2022

Authorised Signatory

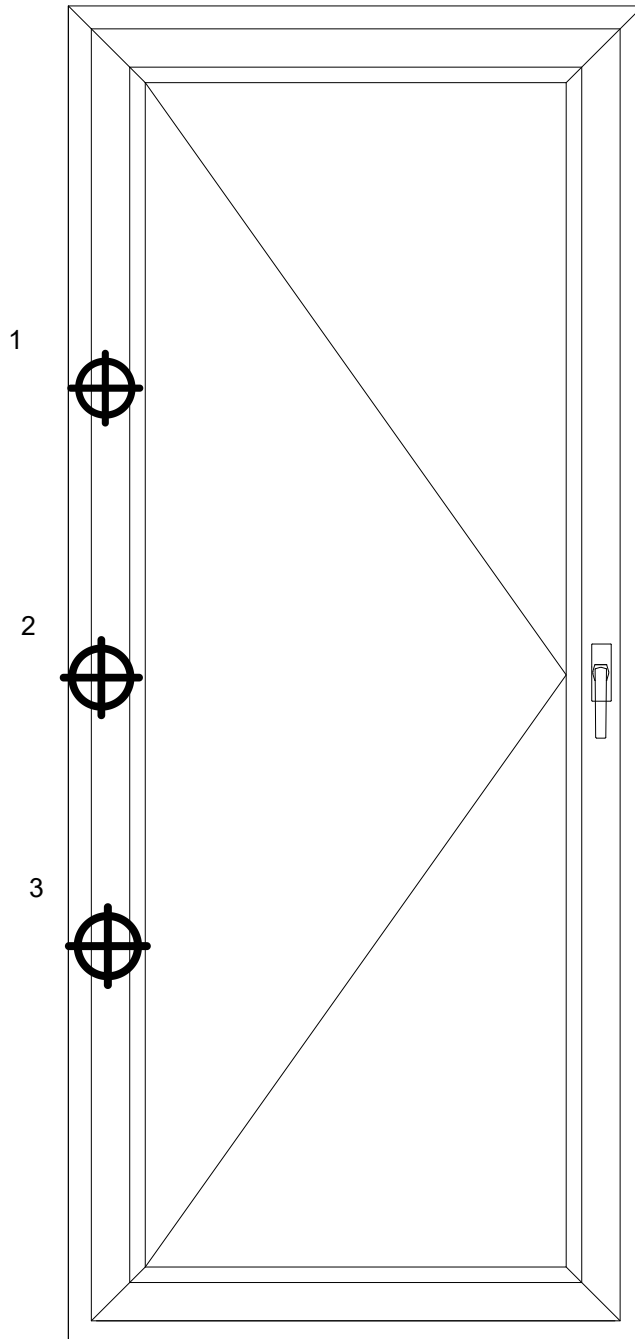

Figure 1; indoor view of the test sample showing the displacement measurement locations

Displacement transducer locations;

1. Door sash longest span between multi points top
2. Door sash longest span between multi points mid span
3. Door sash longest span between multi points Bottom

Table 1

Structural Performance

DATAFILE:2021-009-S3		Test Number: ST1			Date: 15/03/2022		
Member	Pressure (kPa)	Displacements (rounded to 0.1 mm)			Bending Deflection (Rounded to 0.01 mm) $DC - \frac{(D1 + D2)}{2}$ DEF (mm)	Span L (mm)	SDR L/DEF
		Left or Top D1 (mm)	Centre DC (mm)	Right or bottom D2 (mm)			
1,2,3	Tilt & turn sash longest span between multi points						
	0.31	0.4	0.5	0.2	0.2	590	3121
	0.64	1.1	1.1	0.7	0.3		2342
	0.95	1.7	1.8	1.2	0.3		1689
	1.20	2.7	2.7	1.9	0.4		1333
	1.60	3.8	3.8	2.7	0.6		1067
	0.00	0.0	0.0	0.0	0.0		#DIV/0!
	-0.32	-0.2	-0.4	-0.3	-0.1		-5748
	-0.63	-0.5	-0.7	-0.6	-0.1		-5659
	-0.96	-0.9	-1.0	-0.9	-0.2		-3842
	-1.20	-1.1	-1.3	-1.2	-0.2		-3499
	-1.60	-1.7	-1.8	-1.6	-0.2		-3176
	0.00	0.0	-0.1	-0.2	0.0		61458

Appendix A – Test Parameters and Procedures

1 Details

This appendix summarises details of the following Australian Standards:

- AS2047-2014 Windows and externally glazed doors in buildings, Section 2 Performance (inc. Amendments 1 & 2)
- AS4420.1-2016 Windows, external glazed, timber and composite doors-Methods of test

2 Preparation for Tests: AS4420.1-2016, Clause 2

Test description

Prior to commencement of the main tests listed below, any operable windows or doors are to be opened and closed five (5) times. If the test sequence does not commence with the deflection test the sample is to be subject to positive or negative wind pressures being 50% of the nominated SLS test pressures.

3 Deflection Test: AS4420.1-2016, Clause 3

Test Description

Measurements of movement of critical structural members are taken at a range of test pressures in order to determine if the bending of the members exceeds the nominated requirements.

Test Parameters

Test Pressure: is dependent on the type of building nominated by the client-

Housing: Based on Window Rating nominated by client as given in the following table:

Window Rating	Test Pressure (Pa)	
	General	Corner Window
N1	400	600
N2	400	600
N3	600	800
N4	800	1200
N5	1200	1800
N6	1600	2500
C1	600	800
C2	800	1200
C3	1200	1800
C4	1600	2500

Residential or commercial buildings

The test pressures shall be the positive and negative Serviceability Limit State Pressures.

Test Pressure Steps: as given below

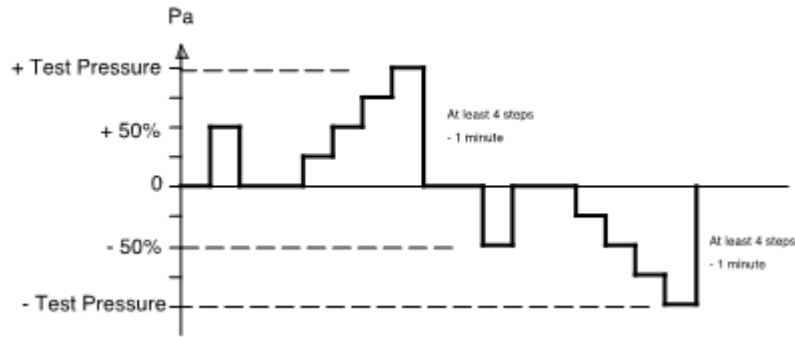

Pass / Fail criteria:

Maximum deflection for structural members -

Windows and Sliding Doors: Span/250

Doors other than sliding: Span/100

4 Operating Force Test: AS4420.1-2016, Clause 4

Test Description

The forces required to operate doors and windows are measured to test compliance with the requirements.

Test Parameters

Test measurements: The forces required to initiate and sustain movement of the door/sash in both directions of movement are recorded.

Pass / Fail criteria: Forces shall not exceed the following

Product type	Force (N)	
	Initiate	Maintain
Horizontal Sliding Window	110	90
Vertical Sliding window	200	160
Horizontal sliding door	180	110
Swinging Door	60	20
Projecting sash(no operator)	160	80

5 Air Infiltration Test: AS4420.1-2016, Clause 5

Test Description

Air leakage through the entire test sample is measured at the nominated pressures in order to determine if it exceeds the allowable rate.

Test Parameters

Pass / Fail criteria : Maximum air infiltration shall not exceed the following

Air infiltration level	Pressure Direction	Maximum Air infiltration, L/s.m2
		Test Pressure 75 Pa
Low	Positive & Negative	1.0
High	Positive	5.0

6 Water Penetration Resistance Test: AS4420.1-2016, Clause 6**Test Description**

Water is sprayed onto the outdoor face of the test sample with air pressure simultaneously being applied across it to determine if unacceptable water leakage occurs.

Test Parameters

Test pressure: The test pressure is dependent on the type of building-

Housing: Based on Window Rating nominated by client as given in the following table-

Window Ratings	Water Penetration resistance test Pressure (Pa)	
	Non-exposed	Exposed
N1, N2	150	200
N3, C1	150	300
N4, C2	200	300
N5, C3	300	450
N6, C4	450	600

Residential or Commercial Buildings:

The test pressure shall be 30% of positive Serviceability Limit State Pressure but not less than 150 Pa.

Test duration: The test pressure shall be maintained for 15 minutes.

Water application rate: 0.05 litre per second per square metre of sample area.

Pass / Fail criteria :

“Windows for Class 1 buildings shall be subjected to the water penetration resistance test in accordance with AS 4420.5, under the test pressures specified in Table 2.4. During and at the completion of the test there shall have been no penetration of uncontrolled water. Uncontrolled water is defined as-

- (a) water that is not contained in a purpose-built drainage area;

6 Water Penetration Resistance Test(continued)

- (b) water that wets or is likely to wet insulation, fixtures and finishes, reveal linings or window furnishings beyond the window frame; or
- (c) water that lies on transoms, rails, sills, etc., that has no designed means of escape to the outside of the product via the drainage system.

Acceptable water penetration is not deemed a failure if-

- (i) minor splashing occurs due to air infiltration, within 1 min after change of pressure;
- (ii) minor, intermittent leakage on the indoor side of openable sashes, which is contained on sash gaskets, sill tracks and thresholds that are part of a drainage system that allows water to flow to the outside of the product at cessation of the test (constant streams and regular dripping would be regarded as failure); or
- (iii) water running down the indoor face of louvers, which is completely contained within a purpose-built drainage area.

7 Ultimate Strength Test: AS4420.1-2016, Clause 7

Test Description

Air pressure greater than the design pressure is applied across the test sample in order to demonstrate that it has a suitable structural safety margin.

Test Parameters

Test Pressure: is dependent on the type of building nominated by the client-

Housing: Based on Window Rating nominated by client as given in the following table-

Window Rating	Test Pressure (Pa)	
	General	Corner Window
N1	600	900
N2	900	1300
N3	1400	2000
N4	2000	3000
N5	3000	4500
N6	4000	6000
C1	1800	2700
C2	2700	4000
C3	4000	5900
C4	5300	8000

Residential or Commercial Buildings: the test pressure shall be the Ultimate Limit State Pressure.

Pass / Fail criteria:

Windows shall not collapse when subjected to the test pressures for a period of ten (10) seconds. Collapse is defined as any one, or any combination, of the following:

- (a) Failure or dislodgement of any glazing.
- (b) Dislodgment of a frame or any part of a frame.
- (c) Removal of a light, either with or without its framing sash, from a frame.
- (d) Loss of support of a frame, such as when it is unstable in its opening in the building structure.
- (e) Failure of any sash, locking device, fastener or supporting stay allowing an opening light to open.

8 Retesting (If Required)

Clause 2.4 of AS4420.1 states:

“If the test specimen requires modification to gaskets, seals or drainage details, then the operating force, air infiltration and water penetration tests shall be repeated in full.

Before retesting, all accessible areas of the test specimen shall be dry and the specimen checked for being operable. The test specimen shall first be preloaded to 50% of either the positive or negative SLS test pressure for one minute. The test specimen shall then be inspected after positive preload to ensure there is no residual water visible in the system. If residual water is evident, the test specimen shall be left, or the positive air pressure pre-loading extended, until such time as the system is dry.

Any modification to the test specimen shall be noted on the respective drawing and the amendment coded thereon.

Appendix B – Details of the test sample

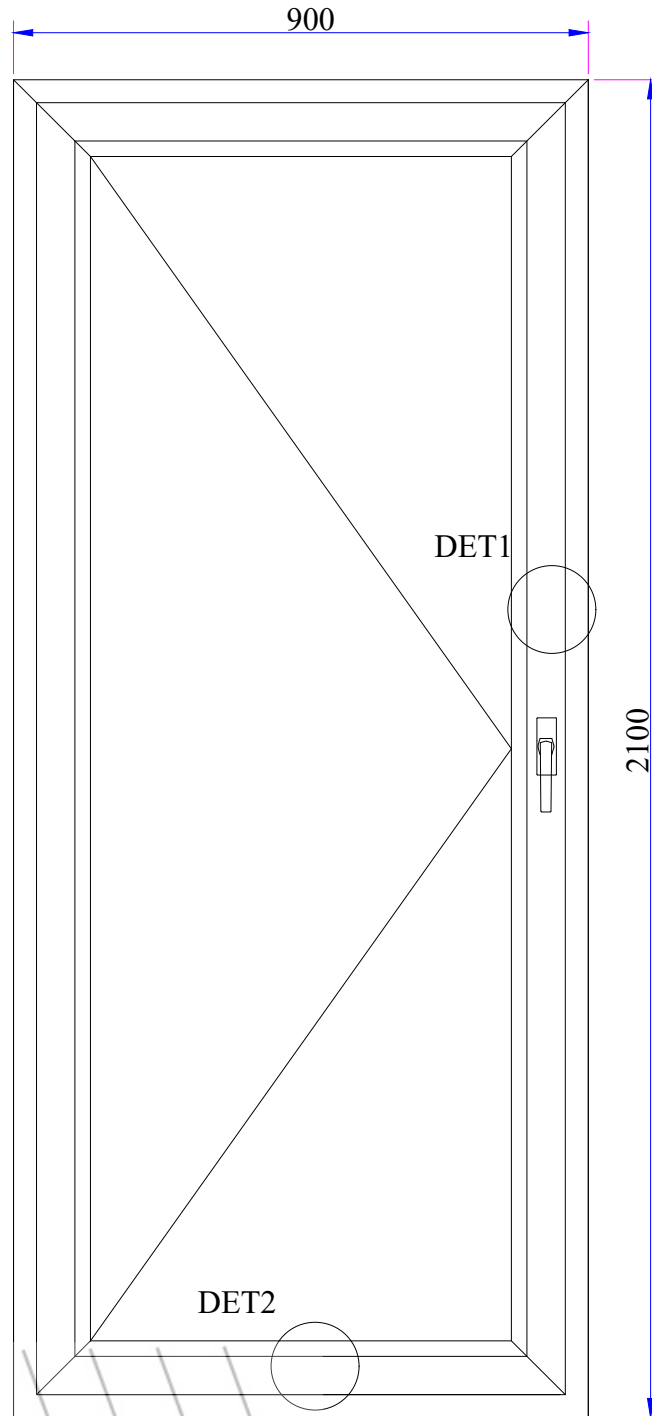

Drawing Attached 92mm Entry Door Multi Lock Gear – Siegenia Door gear Product code – TGKT3030-100010
TGKT Door Latch Plate TRFR0201
Security Stricker Plate TRSK2620-100010
EPDM Seal
92mm Hoppe Entry Door Handle
65/55 Brass Barrel

DET 1

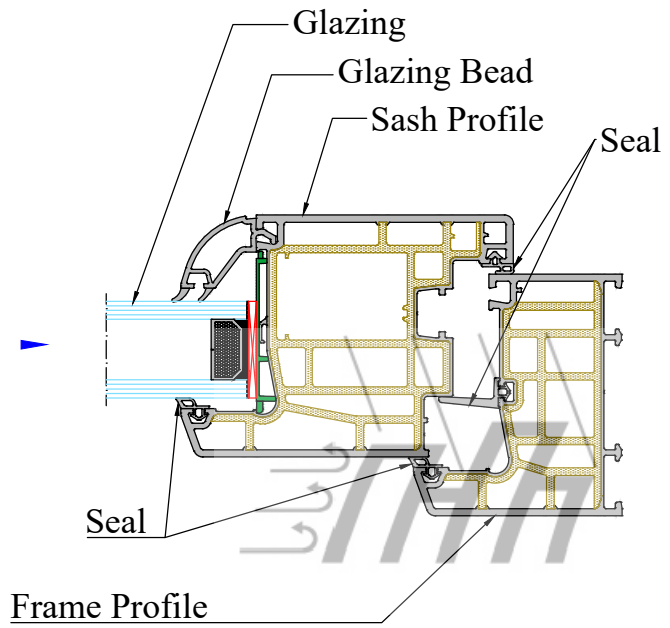

DET 2

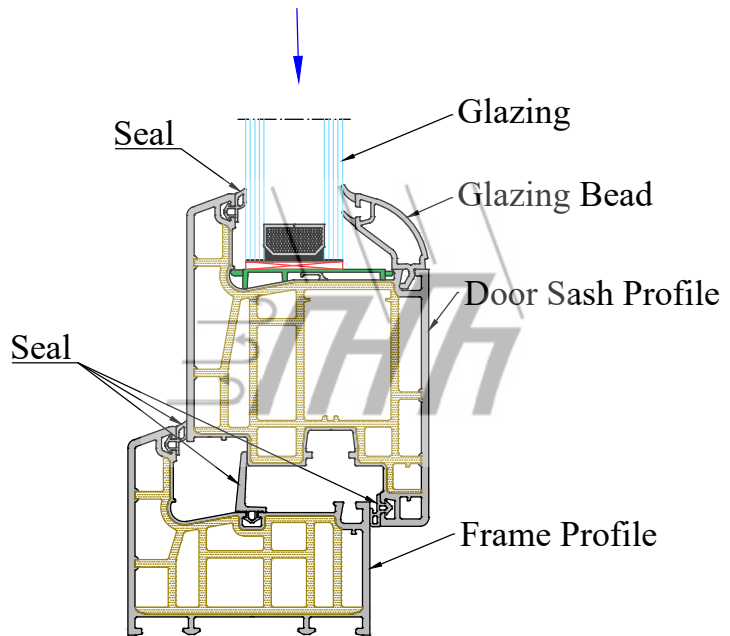

Door Sash - Water Discharge and Vacuum Channels

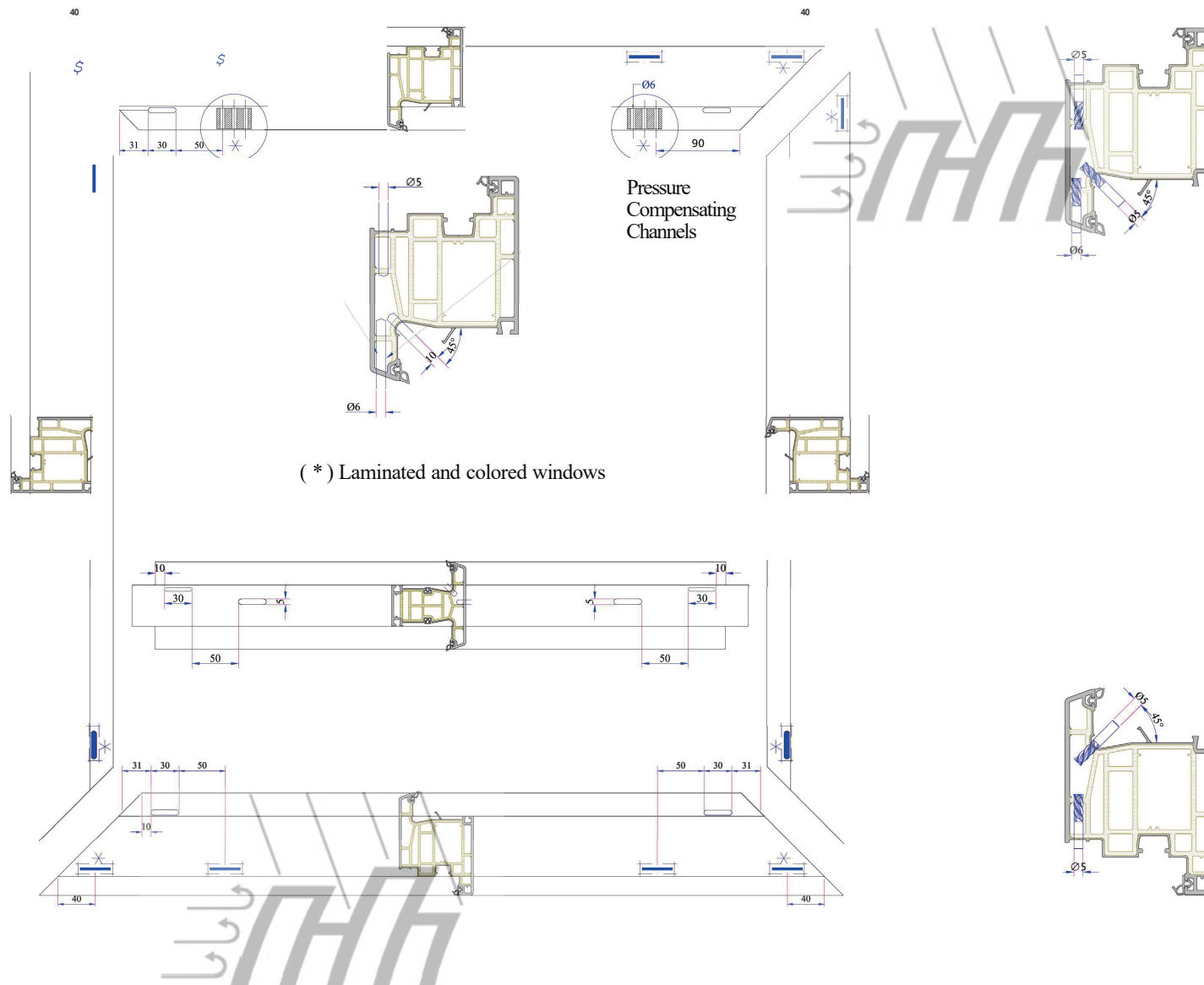

The right to change the technical details belongs to ADO Group. @

Siegenia TGKT Door Latch Plate

Product information

Latch plates for 12mm timber and French systems.



Product code	Description	Side	System	Profile	Packaging unit
TRFR7671	TGKT door latch plate	right	slave	gear mount	25
TRFR7672	TGKT door latch plate	left	slave	gear mount	25

Siegenia TGKT Door Latch Plate - uPVC

Product information

Latch plates for uPVC profiles.



Product code	Description	Side	System	Profile	Packaging unit
TRFR0181	TGKT door latch plate	right	uPVC	Kommerling	25
TRFR0182	TGKT door latch plate	left	uPVC	Kommerling	25
TRFR0201	TGKT door latch plate	right	uPVC	Deceuninck	25
TRFR0202	TGKT door latch plate	left	uPVC	Deceuninck	25
TRFR0211	TGKT door latch plate	right	uPVC	Rehau	25
TRFR0212	TGKT door latch plate	left	uPVC	Rehau	25
TRFR0221	TGKT door latch plate	right	uPVC	Veka	25
TRFR0222	TGKT door latch plate	left	uPVC	Veka	25
TRFR0251	TGKT door latch plate	right	uPVC	Aluplast 4000	25
TRFR0252	TGKT door latch plate	left	uPVC	Aluplast 4000	25
TRFR0281	TGKT door latch plate	right	uPVC	Aluplast 2000	25
TRFR0282	TGKT door latch plate	left	uPVC	Aluplast 2000	25

Siegenia TGKT Door Gear - No Deadbolt

Product information

Handle operated entrance door gear without deadbolt. 8mm spindle and 92 PZ.

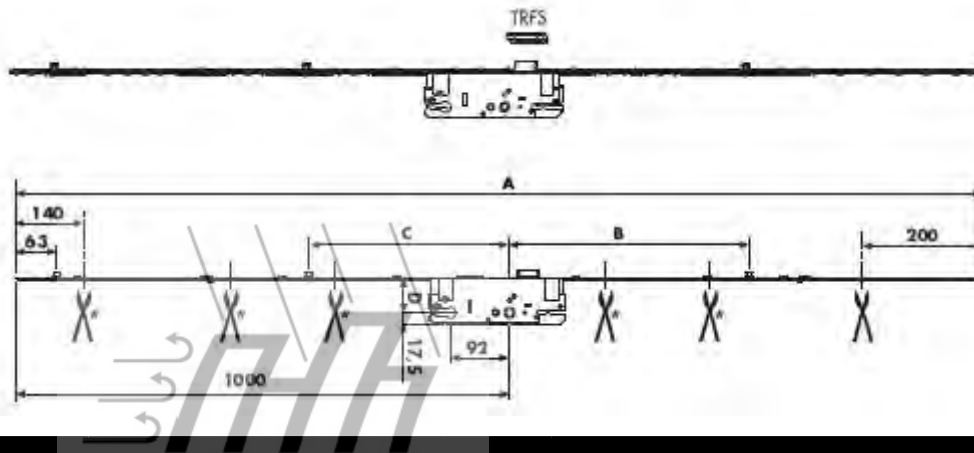

Product code	Description	Dimensions (mm)					
		A	B	C	D	Screws	Packaging unit
TGKT3030-100010	Door gear DB 35/92/8	1960	460	311	35	8	5
TGKT3070-100010	Door gear DB 50/92/8	1960	460	311	50	8	5